

Technical data sheet



Product features

Fry-top griddle plate 65x48 electric chromed combined counter top 400 V

Model	SAP Code	00000994
--------------	-----------------	----------



- Top type: Combined
- Griddle dimensions [mm x mm]: 650 x 480
- Griddle thickness [mm]: 10.00
- Container for liquid fat: Yes
- Independent heating zones: Separate control for each heating zone
- Maximum device temperature [°C]: 300
- Surface finish: polished chrome 0.03 mm
- Removable rim: No

SAP Code	00000994	Power electric [kW]	6.000
Net Width [mm]	658	Loading	400 V / 3N - 50 Hz
Net Depth [mm]	541	Griddle dimensions [mm x mm]	650 x 480
Net Height [mm]	285	Top type	Combined
Net Weight [kg]	43.00		

Technical data sheet



Technical drawing

Fry-top griddle plate 65x48 electric chromed combined counter top 400 V

Model	SAP Code	00000994
-------	----------	----------

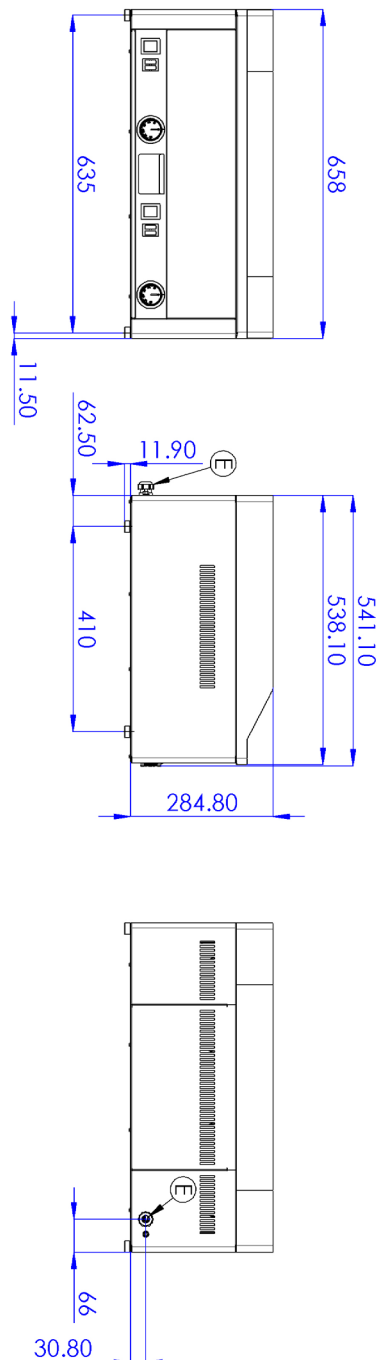

Fry-top griddle plate 65x48 electric chromed combined counter top 400 V

Model

SAP Code

00000994

1

All-stainless design

long life
resistance of AISI 304 stainless steel material
the material does not cut

- savings on service interventions
- easy cleaning and maintenance of equipment

2

Degree of protection of the control elements IPX4

maintenance-free system
resistance to splash water
long life

- savings on service interventions
- easy cleaning and maintenance of equipment

3

Outlet for waste liquids

ensures that oil drips into the socket

- easy maintenance
- easy cleaning

4

High non-removable hem

better hygienic conditions
preventing grease from splashing onto ancillary equipment

- easy maintenance
- easy cleaning

5

Combined plate made of chrome-plated steel

the product bakes less and is easier to clean
a good warming of the meat with a groove

- time-saving in food preparation
- easy preparation of different types of dishes

6

Cooking unit for use on a table or on a base

variable use
the possibility of placement in smaller spaces

- easy handling
- cost savings on substructure

Technical data sheet



Technical parameters

Fry-top griddle plate 65x48 electric chromed combined counter top 400 V

Model

SAP Code

00000994

1. SAP Code:

00000994

2. Net Width [mm]:

658

3. Net Depth [mm]:

541

4. Net Height [mm]:

285

5. Net Weight [kg]:

43.00

6. Gross Width [mm]:

640

7. Gross depth [mm]:

725

8. Gross Height [mm]:

410

9. Gross Weight [kg]:

45.00

10. Device type:

Electric unit

11. Construction type of device:

Table top

12. Power electric [kW]:

6.000

13. Loading:

400 V / 3N - 50 Hz

14. Protection of controls:

IPX4

15. Material:

AISI 430

16. Indicators:

operation and warm-up

17. Surface finish:

polished chrome 0.03 mm

18. Maximum device temperature [°C]:

300

19. Minimum device temperature [°C]:

50

20. Adjustable feet:

Yes

21. Griddle dimensions [mm x mm]:

650 x 480

22. Griddle thickness [mm]:

10.00

23. Container for liquid fat:

Yes

24. Independent heating zones:

Separate control for each heating zone

25. Removable rim:

No

26. Uniform heating:

Yes

Technical data sheet



Technical parameters

Fry-top griddle plate 65x48 electric chromed combined counter top 400 V

Model

SAP Code

00000994

27. Top type:

Combinated

28. Cross-section of conductors CU [mm²]:

0,75

- Výkon (kW): 3,3-3,7 (230 V)